

A DYNAMIC ARCHITECTURE  
EVOKES THE SPIRIT OF ROWING

# UBC BOATHOUSE

JOHN M.S. LECKY UBC BOATHOUSE





John M.S. Lecky UBC Boathouse



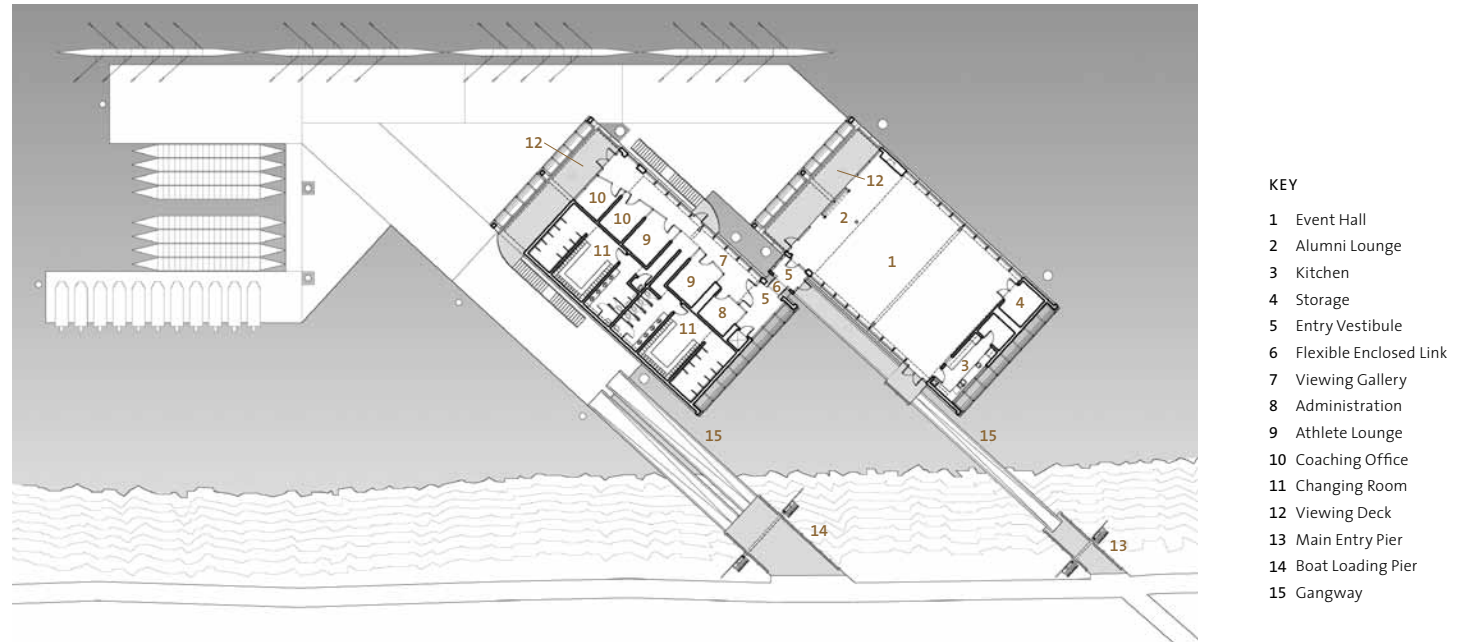

## ARCHITECTURE

**THE JOHN M.S. LECKY UBC BOATHOUSE** is located in Richmond, British Columbia on the Middle Arm of the tidal estuary of the Fraser River and is accessed through a public park on the bordering dike. The floating structure provides training facilities for the University of British Columbia Thunderbirds and St. George's School rowing teams, and also provides a venue for community programs, recreational rowing and dragon boating.

The traditional architectural vocabulary associated with rowing boathouses goes back to the origin of rowing as a sport which began more than a century ago and was often associated with exclusive British and Ivy League universities. Now, with the popularity of rowing spreading to other sectors of society, the UBC Boathouse appropriately creates a more open and contemporary expression related to the function, context and physics of the sport.

The architecture emphasizes transparency—maximizing views in and out of the public spaces; luminosity—capturing the ever-changing reflections of light off the river, and the dynamic quality of rowing as expressed in the form and structure of the building.

The building is divided into two modules linked by a flexible bridge and floating docks that are oriented to afford views

*“The architecture reveals its purpose by evoking the essential qualities of the rowing experience: a gentle presence on the river, the luminous properties of the water environment, and a refined athletic technique—requiring smooth movement, balance, power, cadence and efficiency.”*

CRAIG DUFFIELD, LEAD DESIGN ARCHITECT — MCFARLAND MARCEAU ARCHITECTS

downstream from the park. The modules organize the building into public and private zones at the upper level, and into separate groupings of rowing teams at the lower level. The clubhouse forms are rendered in a tight composition of curving wood structure, sleek metal detailing and large areas of glazing. These shapes float above the simple forms of the boat storage bays, which are clad in a continuous skin of translucent polycarbonate panels.

Floating the structure places the boat-storage areas level with the water, making launching much easier given the 16-ft (5-m) tidal variation on this stretch of the river. It also places the building in a dynamic relationship with its surroundings, with the changing tides bringing the public functions of the building level with, and visible from, the adjacent dike.



---

#### FACTS

- This 14,000-ft<sup>2</sup> (1,300-m<sup>2</sup>) floating structure was fabricated off site and towed into its position adjacent to the south bank on the Middle Arm of the Fraser River. Styrofoam-filled concrete rafts provide floatation for the bifurcated building, which is primarily made of heavy timber and engineered wood post and beam construction
  - Primarily serving the needs of competitive and recreational rowing teams, the facility also hosts dragon boaters and community paddlers, and is a venue for other community events
  - The floating structure brings boat storage down to river level, making launching of boats (known as “rowing shells”) easier and more efficient
  - The angled plan means that the shells—lightweight, delicate and up to 60 ft (18 m) in length—may be transferred from storage racks to the water with minimal manoeuvring, making the process safer and faster, and increasing the overall capacity of the facility
-



## STRUCTURE

**THE BUILDING IS MOORED BY STEEL** anchor pilings and accessed by aluminum gangways. A heavy timber superstructure is constructed on top of concrete floats. These are literal "raft" foundations, comprising an egg-crate arrangement of concrete beams surrounding Styrofoam-filled cavities.

The rigorous development of the basic structural module for the building—the 14-ft high, 22×80-ft (4.2-m high, 7×24-m) boat bay—was based on the most efficient layout for the storage of rowing shells, oars and other equipment. The lower level is framed with a primary structure of 8×8-in (203×203-mm) solid Douglas-fir posts and Parallam beams. Secondary support for the upper floor is provided by TJI floor joists. The frames on the exterior walls are connected by steel-rod cross bracing that provides lateral rigidity to the structure.

On the second storey, slim 3.5×5-in (90×130-mm) glulam posts impose a rhythm on the aluminum-framed window walls to the north and south of the event hall. Above, the roof structure comprises curved glulam purlins that vault lightly over an elliptical steel beam

*"The structure responds to the needs of the building—simple post and beam on the lower level storage areas, and a more elegant, exposed roof structure in the public areas above. The combination of steel and glulam makes for an efficient lightweight solution that also captures some of the dynamic quality of the sport of rowing."*

PAUL FAST, PARTNER – FAST + EPP STRUCTURAL ENGINEERS

located at mid span. The exposed roof decking is 2×4-in (38×89-mm) Douglas-fir with plywood sheathing above.

The 19-in (480-mm) deep elliptical steel section spans between two 10-in (250-mm) diameter HSS columns that rise through the building from the concrete float, and is connected to the columns by steel plates. Pairs of diagonal struts are welded to the tube at 19 in (475 mm) centres, holding the 12-in (304-mm) glulam purlins a further 20 in (500 mm) aloft. The strut-to-glulam connection is made with steel plates and lag screws.





---

#### FACTS

- Under the British Columbia Building Code 1998, the building is classified as comprising A2 (assembly) and F3 (storage) occupancies with ancillary office and other support spaces
  - At two storeys and with an area of 14,000 ft<sup>2</sup> (1,300 m<sup>2</sup>), the building is permitted to be of combustible construction, if sprinklered in accordance with NFPA 13, and with the major occupancy areas (boat storage and upper floor clubhouse) separated with a 45-min, fire-rated floor assembly
  - A combination of “char” depth and sprinkler design was used to achieve a 1-hour fire rating for heavy timber supporting the second floor. A sprinkler “water curtain” was used to achieve the required rating adjacent to the exit stairs
-



## WOOD AND SUSTAINABILITY

**THE DESIRE WAS TO MAKE THIS A BUILDING** that would not only respond to its site in a unique and dynamic way, but would also be energy efficient and have a minimal impact on the surrounding environment.

The decision to prefabricate the structure and float it into place was key to realizing these goals, and the heavy timber frame was ideally suited to this purpose, being made of locally sourced, durable material with low embodied energy. Life cycle analysis informed the selection of other materials including profiled metal cladding and western red cedar.

Because the building is accessed by ramps from the dike, there is no disturbance of the environmentally sensitive intertidal zone, and the angled configuration of the plan means there is minimal shading near the shoreline.

The Boathouse relies mostly on natural light and natural ventilation to maintain comfortable interior conditions. At the lower level, the translucent polycarbonate cladding reduces the requirement for artificial lighting, and allows for some passive solar heating. On the upper level, the low-emissivity glazing on the southeast and southwest sides performs a similar function while permitting expansive views of the river and mountains beyond.

The windows on the southeast and southwest sides of the building are protected by screens comprising western red cedar slats mounted on curved steel brackets. These soften the silhouette, strategically frame views from the outdoor decks and provide shading from low-angle sun. Operable windows allow for cross ventilation, and the tempering effect of the river means that the building requires no air conditioning.

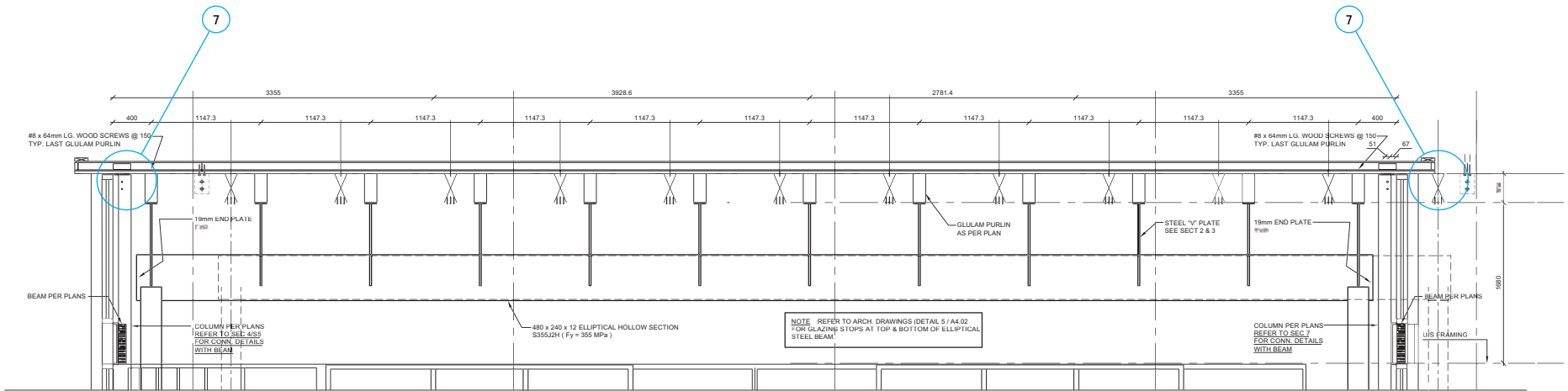

## WHATEVER FLOATS YOUR BOAT

Designing a floating building requires certain special considerations:

- calculating the amount of buoyancy required in the floats—to counteract the dead weight of the building and any anticipated live loads, such as snow—so that the structure achieves the desired amount of freeboard;
- balancing this weight evenly so that the structure sits level in the water; and
- anchoring the building against horizontal wind loads and the river's current (seismic forces are assumed to be attenuated by the water).

The decision to prefabricate the building off site also dictated the division of the building into two distinct parts because each module had to be towed by tugboat from a dry dock located upriver to the site, and had to fit below all the bridges along the tow route.

The design of the flexible bridge link connecting the second storey of the two modules had to accommodate differential movement of up to 17 in (430 mm) in any direction while remaining relatively weather tight. This was solved with a bridge that is hinged on one module and suspended from

rods on the other. The link is protected from rain by a flexible silicone shroud.

With respect to fire rating, an equivalency was also required to allow flexible stainless steel connections at the gangways in lieu of standard sprinkler piping.

Aesthetically, the building is designed to evoke the physics of rowing—the arcing motion described by the oars on each stroke, the balancing of the narrow boat on the water and the efficiency of motion. The taut, metallic form of the second storey is balanced above the quiet luminous presence of the first storey. The Spartan economy of the light-weight rowing shell informs the efficient use of space and the simplicity of the exposed curved roof structure. The supporting structure of steel tubes and struts references the slender oars and steel outriggers (which suspend the pivot-points of the oarlocks, 2 ft (600 mm) outboard from the hull of the rowing shell in order to increase leverage).



7

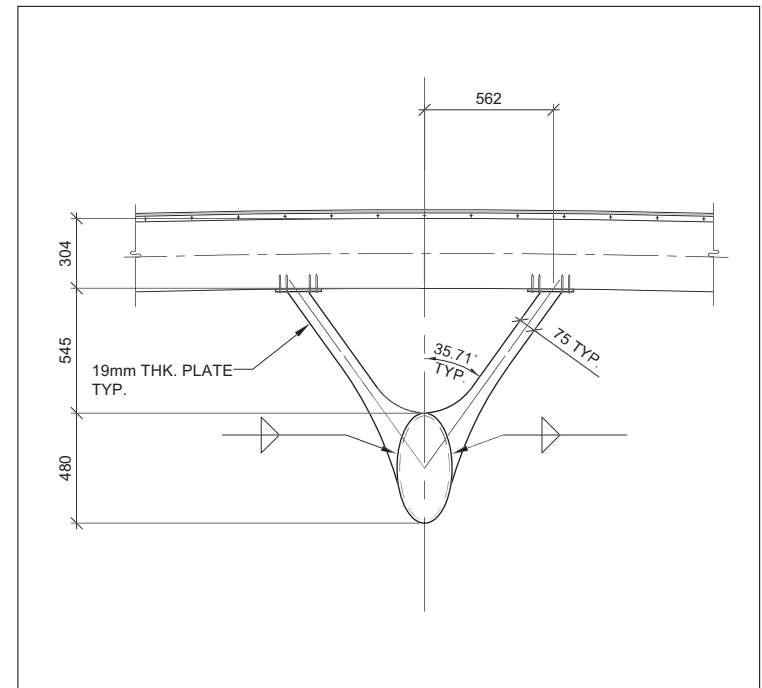
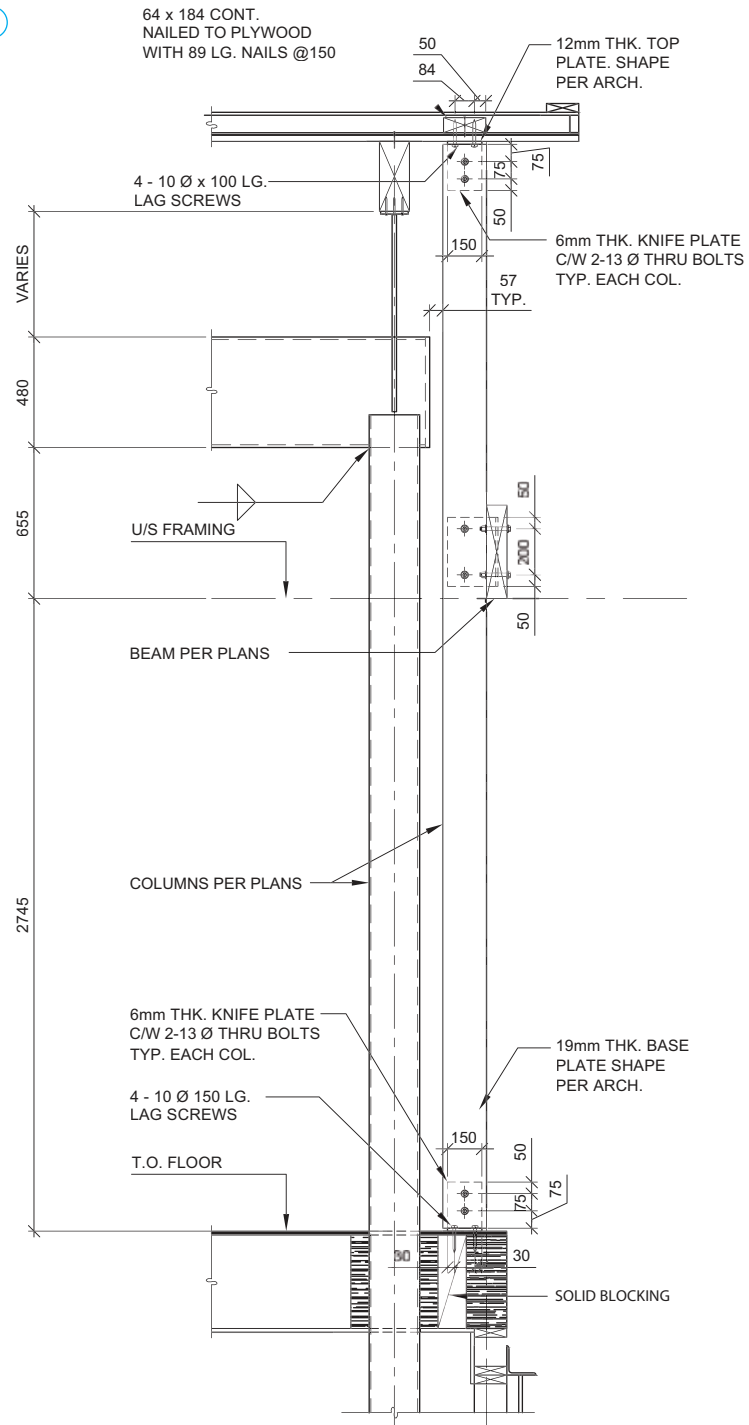



*“This is a wonderful building to work in—it is warm, peaceful and full of natural light. I love the contemporary look and the fact that you are always aware of the surroundings, the changing weather and the varying moods of the river. I think it is these qualities that make it such a popular venue.”*

**RENA VARNES, FACILITY MANAGER – UBC BOATHOUSE**

JOH

# H.N.M.S. LECKY U



## PROJECT CREDITS

### CLIENT

University of British Columbia  
(UBC Properties Trust)

### ARCHITECT

McFarland Marceau Architects Ltd.

### STRUCTURAL ENGINEER (SUPERSTRUCTURE)

Fast + Epp Structural Engineers

### STRUCTURAL ENGINEER (FLOATS)

All-Span Engineering and Construction Ltd.

### MECHANICAL ENGINEER

Stantec

### CIVIL ENGINEER

P.S. Turje & Associates Ltd.

### ELECTRICAL ENGINEER

Cobalt Engineering

### MARINE CONSULTANT

Westmar Consultants Inc.

### BUILDING CODE CONSULTANT

Gage-Babcock & Associates Ltd.

### GEOTECHNICAL CONSULTANT

Trow Associates Inc.

### BUILDER (SUPERSTRUCTURE)

Kindred Construction Ltd.

### BUILDER (FLOATS)

International Marine Flotation Systems Inc.

### GLULAM AND TIMBER FABRICATOR

Island Timber Frame Ltd.

### PHOTOGRAPHER

Derek Lepper





FOR TECHNICAL INQUIRIES  
[www.wood-works.ca](http://www.wood-works.ca)  
1-877-929-9663

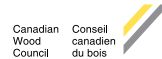

[naturallywood.com](http://naturallywood.com)

British Columbia Wood. Sustainable by Nature. Innovative by Design.

# BC BOATHOUSE